

HANLO

FLUSH PIN GAGES
AND ADAPTORS

CATALOG 82A

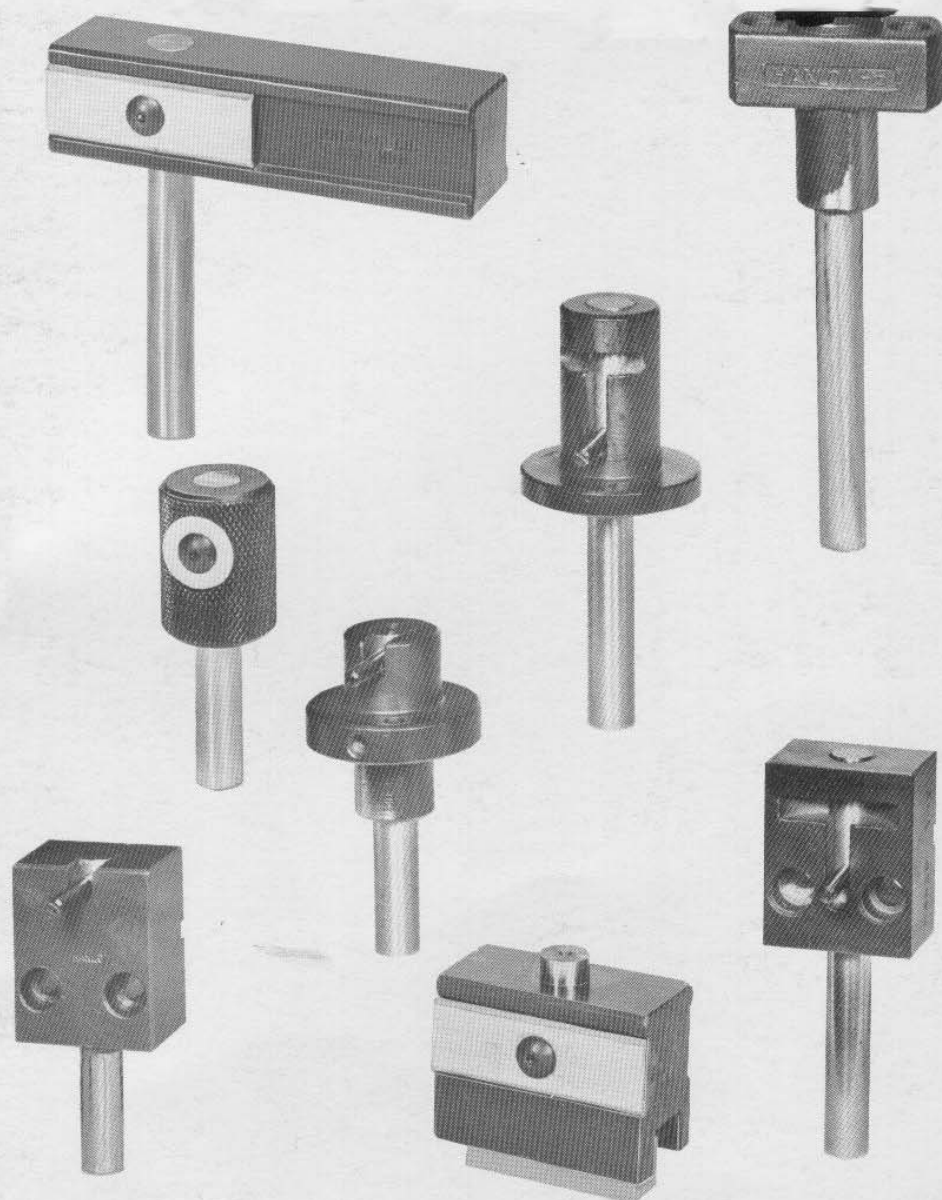

HANLO
GAGES

HANLO

GAGE & ENGINEERING CO.

TABLE OF CONTENTS

<u>Title</u>	<u>Page No.</u>
Barrel Series	1
Model HS	2
"Z" Bar Series with "D" Pin	3
Model HC-2	4
Models HC-3 & HC-4	5
"W" Bar Series	6
Flush Pin Adaptors	7
Adaptor V1	8
Adaptor V2	9
Adaptor V3	10
Adaptor V4	11
Adaptor V5	12
Adaptor Pins	13
Indicator Adaptor for the Barrel Series	14
Indicator Adaptor for the HC Series	15
Complete Gaging Systems	16

BARREL SERIES



ENGINEERING DATA



STANDARD OFF SHELF ITEM

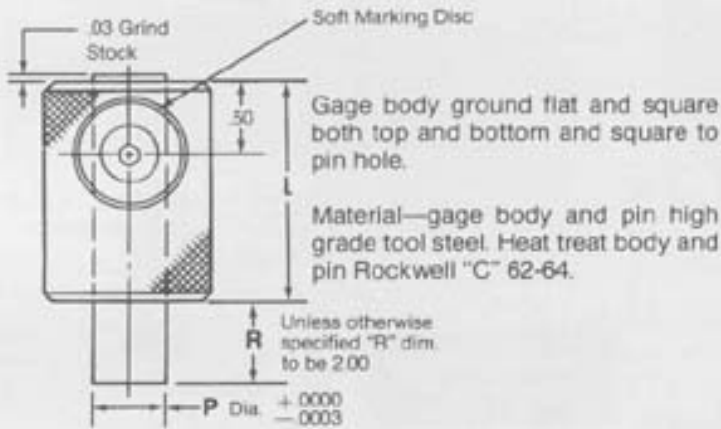

GAGE BLANK - BARREL TYPE

GENERAL DIMENSIONS			
MODEL NO.	P PIN DIA.	D BARREL DIA.	L BARREL LENGTH
250	2500	1.000	1.000
281	2812	1.000	1.000
312	3125	1.000	1.000
343	3437	1.000	1.000
375	3750	1.000	1.250
406	4062	1.031	1.312
437	4375	1.062	1.375
468	4687	1.093	1.437
500	5000	1.125	1.500
531	5312	1.156	1.562
562	5625	1.187	1.625
593	5937	1.218	1.687
625	6250	1.250	1.750
656	6562	1.281	1.812
687	6875	1.312	1.875
718	7187	1.343	1.937
750	7500	1.375	2.000

1000 1.000 1.75 2.50
~~7.000~~
~~2.000~~

APPLICATIONS

Finish grind Model 500 flush pin gage blank barrel type to check .375-.385 X 60° counter-sink diameter step on body.

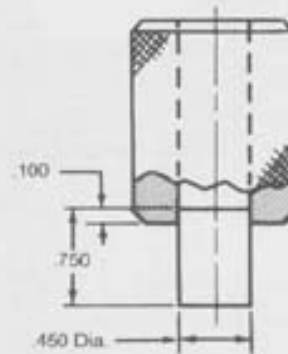
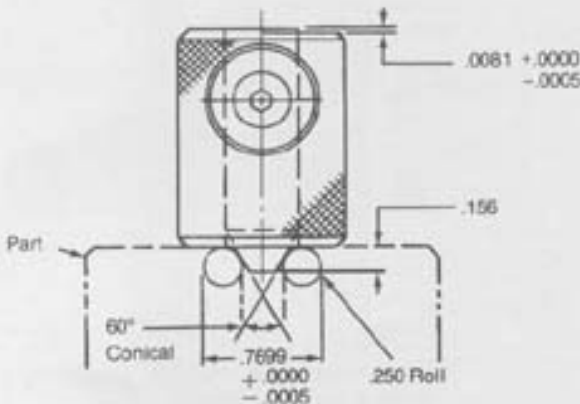

HANLO MODEL 500 GAGE BLANK ALTER AS SHOWN.

When drawing is required, show only the finish grind dimensions.

Tracing template available.

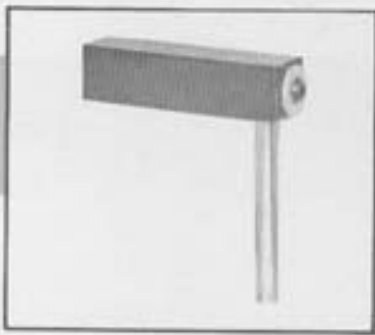

MODEL "HS"

ENGINEERING DATA

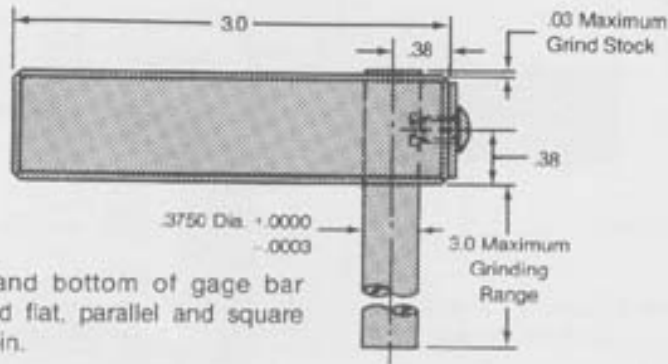

Top and bottom of gage bar ground flat, parallel and square with pin.

Gage pin slip fit clearance:
Maximum .0008
Minimum .0003

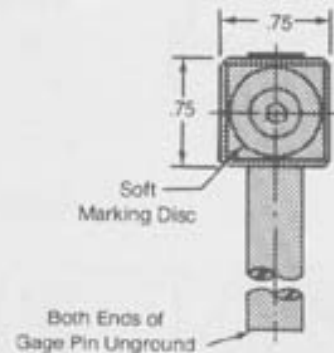

Material—bar and pin high grade tool steel. Heat treat bar and pin Rockwell "C" 62-64.

APPLICATIONS

Finish Grind
Hanlo bar type Model "HS"
Maximum gaging range .635
Minimum gaging range .625
Step on bar.

STANDARD OFF
SHELF ITEM

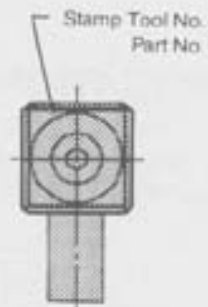
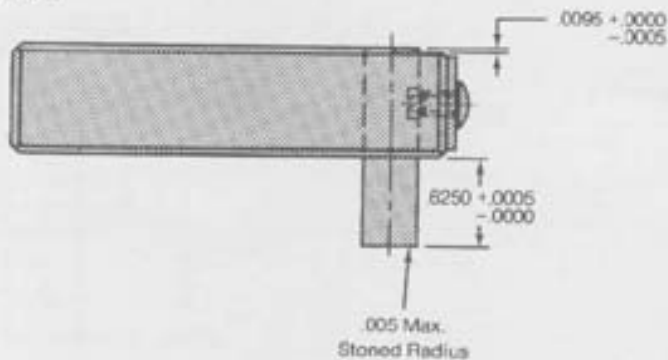

Note: Gage pins longer than 3 inches will be supplied on request.

When drawing is required, show only the finish grind dimensions.

Tracing template available.

"Z" BAR SERIES WITH "D" PIN



ENGINEERING DATA

Top and bottom of bar ground flat, parallel and square with pin hole.

Material—bar and pin high grade tool steel. Heat treat bar and pin Rockwell "C" 62-64.

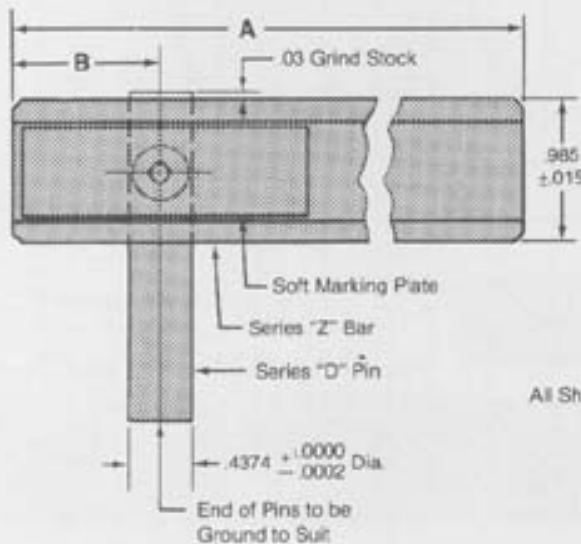

If longer pins are required, specify length

STANDARD OFF SHELF ITEM

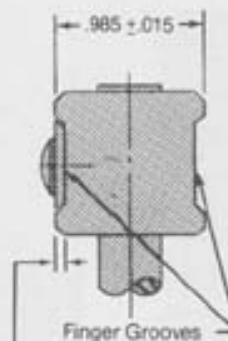

All Sharp Edges Removed

SERIES "D" PINS

PIN LENGTH
D-2 IN.
D-4 IN.
D-6 IN.

SERIES "Z" BAR

BASE SIZES	
A	B
2	1
3	1
3	1 1/4
4	1
4	2
5	1
5	2
5	2 1/4
6	1
6	2
6	3
8	1
8	2
8	3
8	4
10	1
10	2
10	3
10	4
10	5
12	1
12	2
12	3
12	4
12	5
12	6
14	1
14	2
14	3
14	4
14	5
14	6
14	7

ORDERING

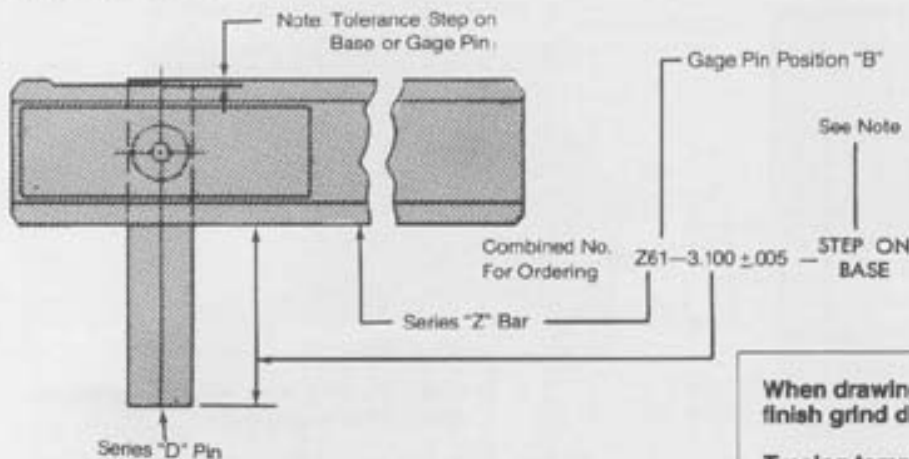

When drawing is required, show only the finish grind dimensions.

Tracing template available.



MODEL HC-2

ENGINEERING DATA

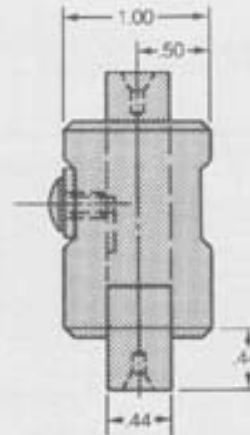
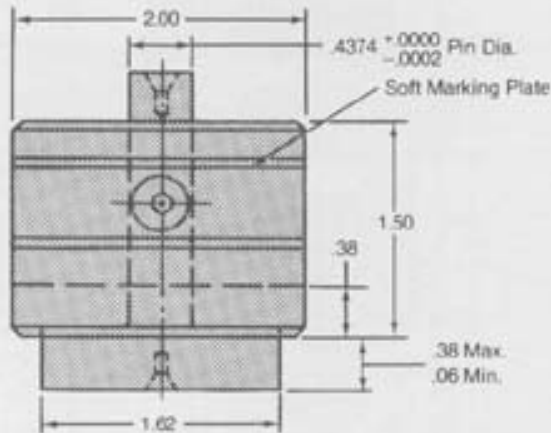

Gage Specifications:
Max. Countersink Dia. 1.50 in.
Min. Countersink Dia. .75 in.

Top and bottom surface of gage body ground flat, parallel and square with hole.

**STANDARD OFF
SHELF ITEM**

APPLICATIONS

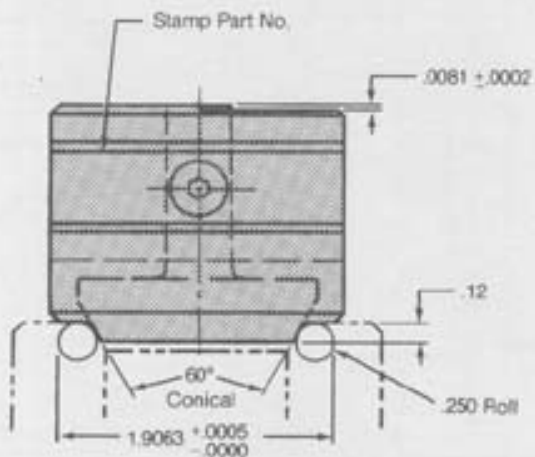

Finish grind Hanlo flush pin gage blank Model HC-2 to check 1.512-1.522 X 60° countersink diameter step on body.

Tolerance step on body or pin.

When drawing is required, show only the finish grind dimensions.

Tracing template available.

MODEL HC-3



ENGINEERING DATA

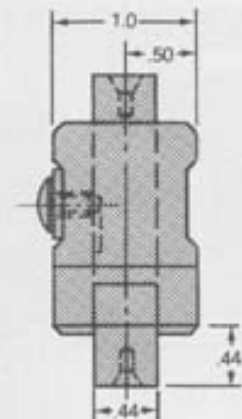
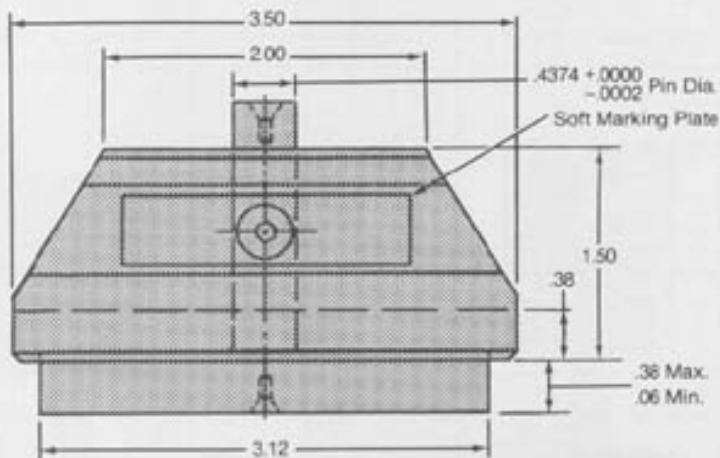

Gage Specifications:
Max. Countersink Dia. 3.00 in.
Min. Countersink Dia. 1.50 in.

**STANDARD OFF
SHELF ITEM**

Top and bottom surfaces of gage body ground flat, parallel and square with hole.

MODEL HC-4

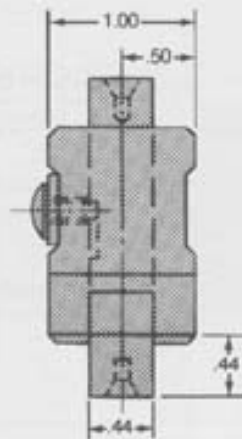
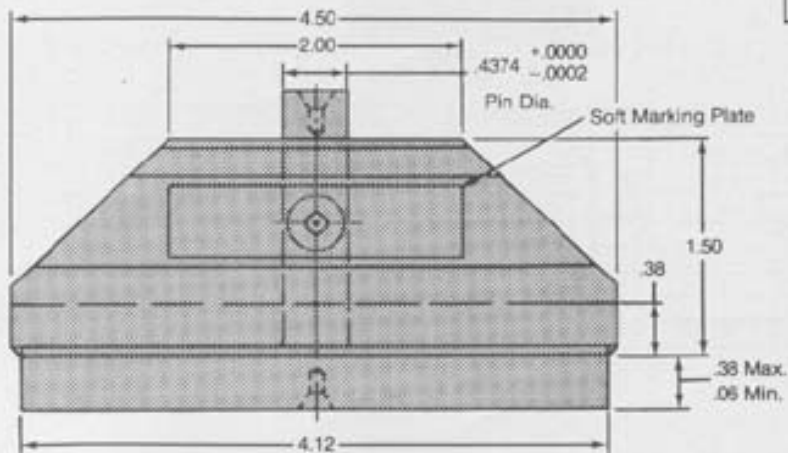
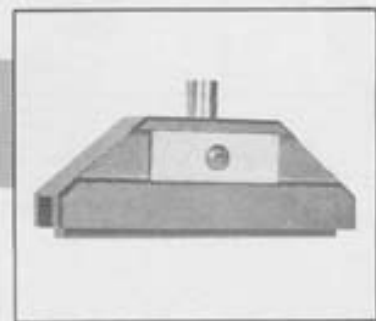

Gage Specifications:
Max. Countersink Dia. 4.00 in.
Min. Countersink Dia. 3.00 in.

Top and bottom surfaces of gage body ground flat, parallel and square with hole.

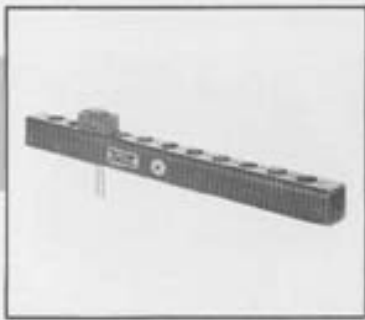

"W" BAR SERIES

ENGINEERING DATA

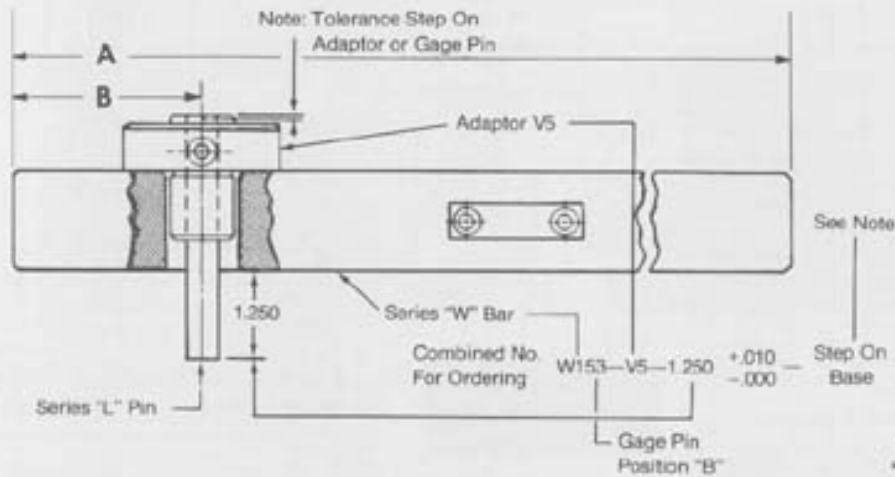

If longer pins are required, specify length

Material: Pin high grade tool steel. Heat treat Pin Rockwell "C" 62-64.
Bar machine steel, .030 minimum case depth. Heat treat Bar Rockwell "C" 50-62.

SERIES "L" PINS

PIN LENGTH
L-2 IN.
L-4 IN.
L-6 IN.





STANDARD OFF SHELF ITEM

SERIES "W" BARS											
SERIES	A	B. GAGE LOCATION FROM END OF BAR									
		1.31	2.62	3.94	5.25	6.56	7.88	9.18	10.50	11.82	13.12
W-13	13.12	1	2	3	4	5					
W-15	15.75	1	2	3	4	5	6				
W-18	18.38	1	2	3	4	5	6	7			
W-21	21.00	1	2	3	4	5	6	7	8		
W-23	23.62	1	2	3	4	5	6	7	8	9	
W-26	26.25	1	2	3	4	5	6	7	8	9	10

When drawing is required, show only the finish grind dimensions.

Tracing template available.

FLUSH PIN ADAPTORS

TYPE VI Series "N" Gage Pin	TYPE V2 Series "N" Gage Pin	TYPE V3 Series "M" Gage Pin	TYPE V4 Series "M" Gage Pin	TYPE V5 Series "L" Gage Pin
				

FEATURES

- Retain flush pin and maintain retracted position.
- A step readout may be provided either on the gage pin or adaptor body.
- A high grade tool steel, hardened, is a rigid standard applied to every gage pin and adaptor body design.
- Dimensional grinding to meet part gaging conditions is the only requirement for adaptability.
- Available, as shown above, are five types of adaptors constructed to meet a variety of special design applications.

When drawing is required, show only the finish grind dimensions.

Tracing template available.



ADAPTOR V1

V1 APPLICATIONS

Dimension from the centerline of keyway to gaging surface of part will determine model series "N" gage pin.

FEATURES

Hanlo adaptor assembly V1 is designed for flat mounting to the special gage design. There is a precision keyway for locating the special gage design. The mounting surface is ground parallel to the gage pin.

The gage pin may be retracted flush with the bottom face of the adaptor body for part loading. The gage pin is held in the retracted position by a spring loaded retainer pin.

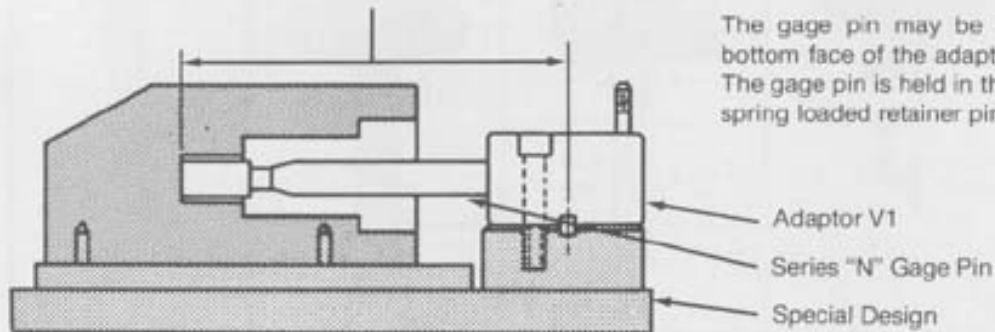

V1 ORDERING

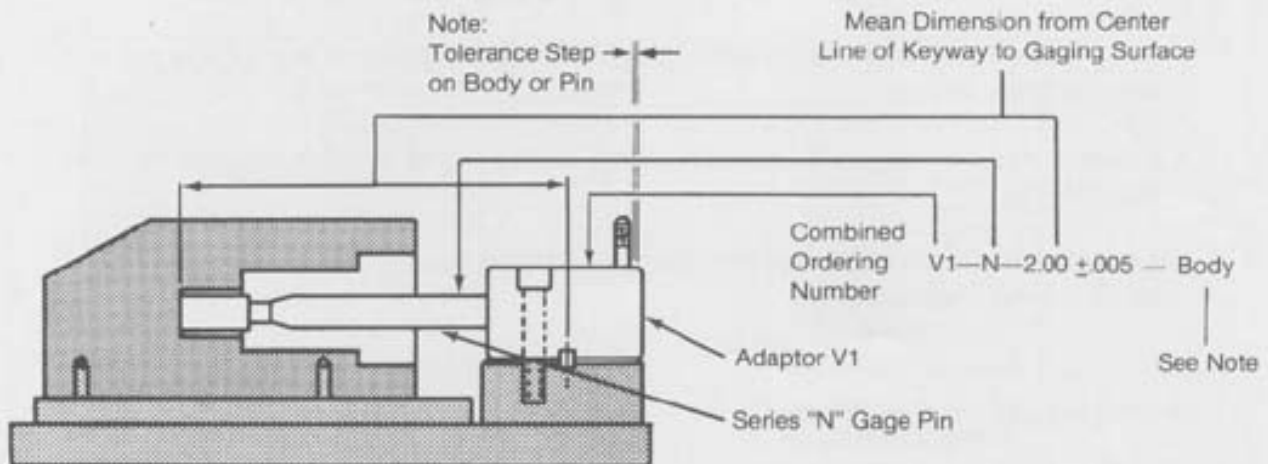

ADAPTOR V2



V2 APPLICATIONS

FEATURES

Hanlo adaptor assembly V2 is designed to be mounted into a clearance hold of the special gage unit.

The gage pin may be retracted flush with the joint face of the adaptor body for part loading. The gage pin is held in the retracted position by a spring loaded retainer pin.

Dimension from the joint face to gaging surface of part will determine model series "N" gage pin.

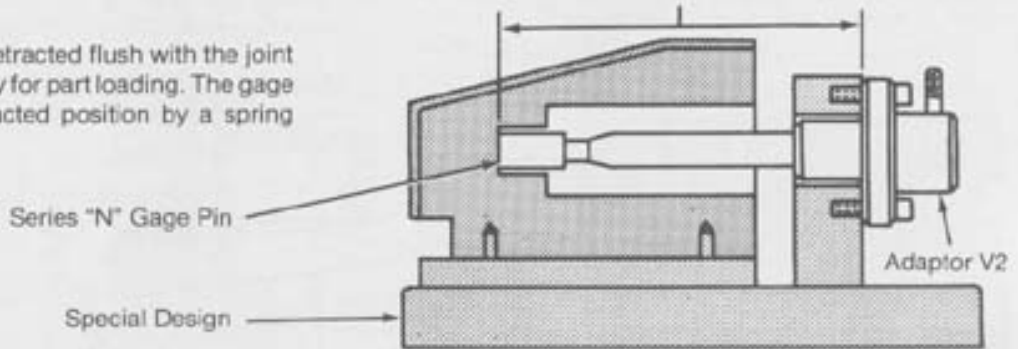

V2 ORDERING

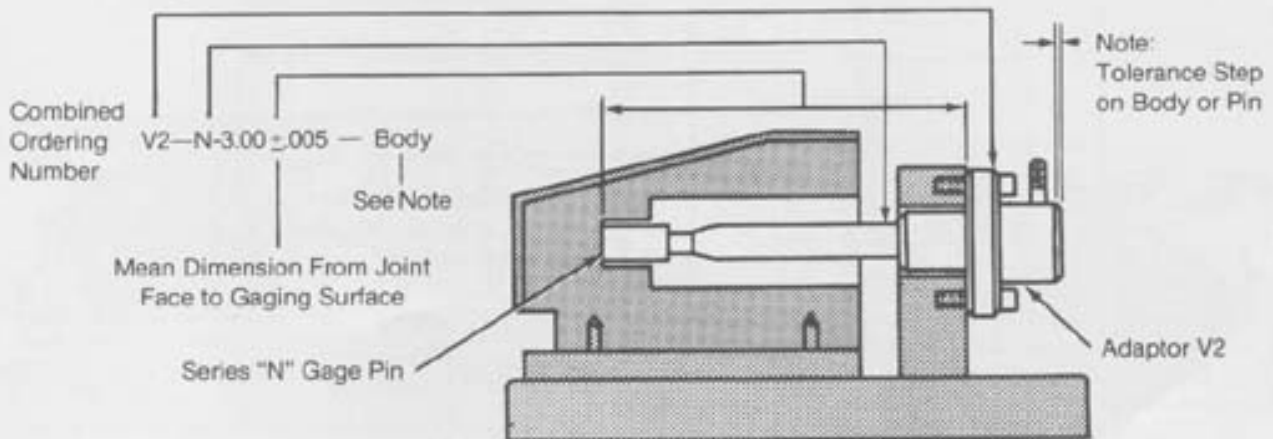



ADAPTOR V3

V3 APPLICATIONS

Dimension from the centerline of keyway to gaging surface of part will determine model "M" gage pin.

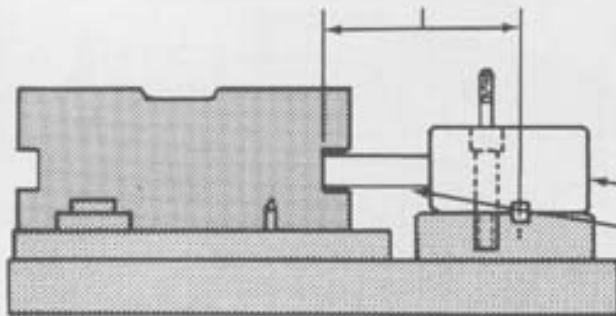

FEATURES

Hanlo adaptor assembly V3 is designed for flat mounting to the special gage design. There is a precision keyway for locating the special gage design. The mounting surface is ground parallel to the gage pin.

Gage pin is retractable $\frac{3}{4}$ inch for part loading. A two-way lock is provided to hold the gage pin in the retracted position.

Adaptor V3
Series "M" Gage Pin
Special Design

V3 ORDERING

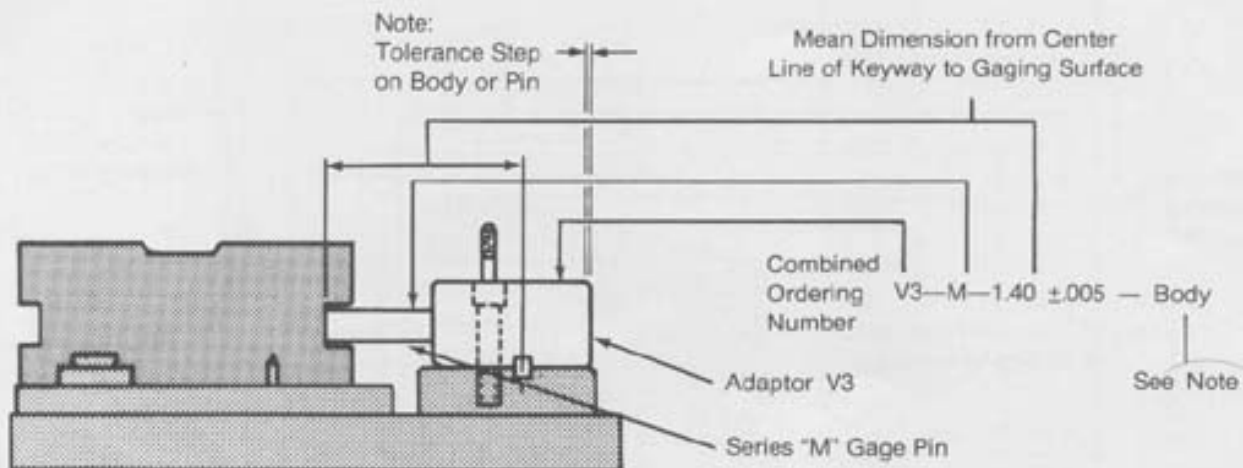

ADAPTOR V4



V4 APPLICATIONS

Dimension from the joint face of gaging surface of part will determine model series "M" gage pin.

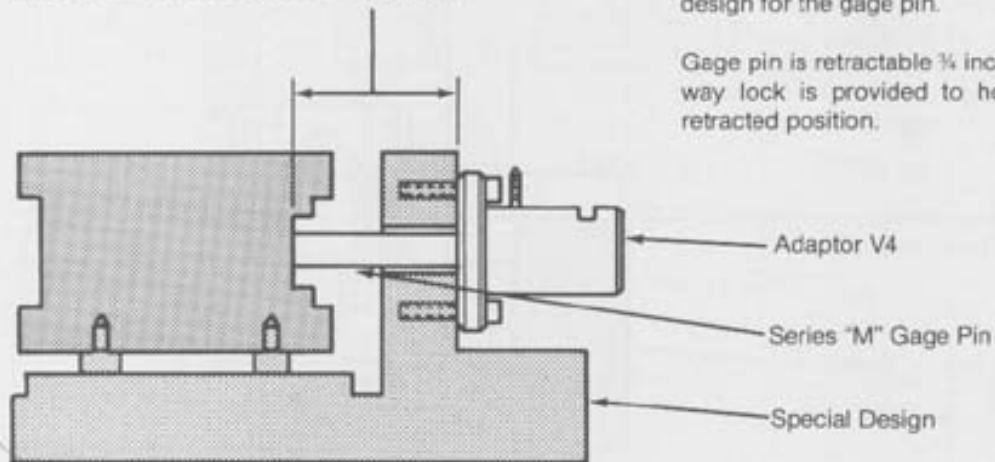

FEATURES

Hanlo adaptor assembly V4 is designed for face mounting, necessitating a clearance hole in the special gage design for the gage pin.

Gage pin is retractable $\frac{3}{4}$ inch for part loading. A two-way lock is provided to hold the gage pin in the retracted position.

V4 ORDERING

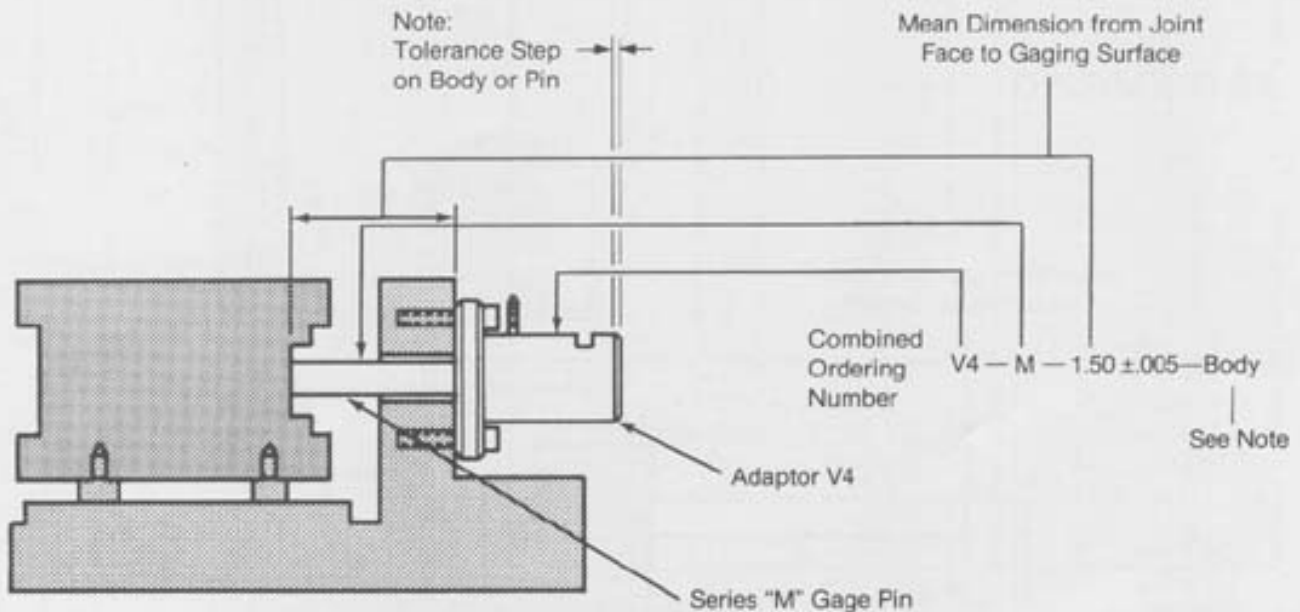



ADAPTOR V5

V5 APPLICATIONS

FEATURES

Hanlo adaptor assembly V5 is designed for mounting into a clearance hole in a special gage design.

Gage pin travel is limited. This unit is designed for gaging conditions where gage pin retraction is usually not necessary because of the special gage design.

Hanlo Series "W" Bar
or Special Design as Shown

Series "L" Gage Pin

Dimension from the joint face of gaging surface of part will determine model series "L" gage pin.

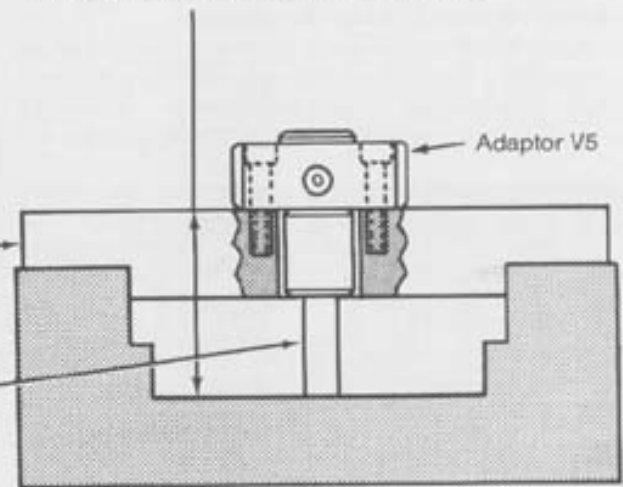

Adaptors and gage pins are manufactured of high grade tool steel, Rockwell "C" 62-64. Surface hardness will not be effected by cut-off or grinding of gage pins.

V5 ORDERING

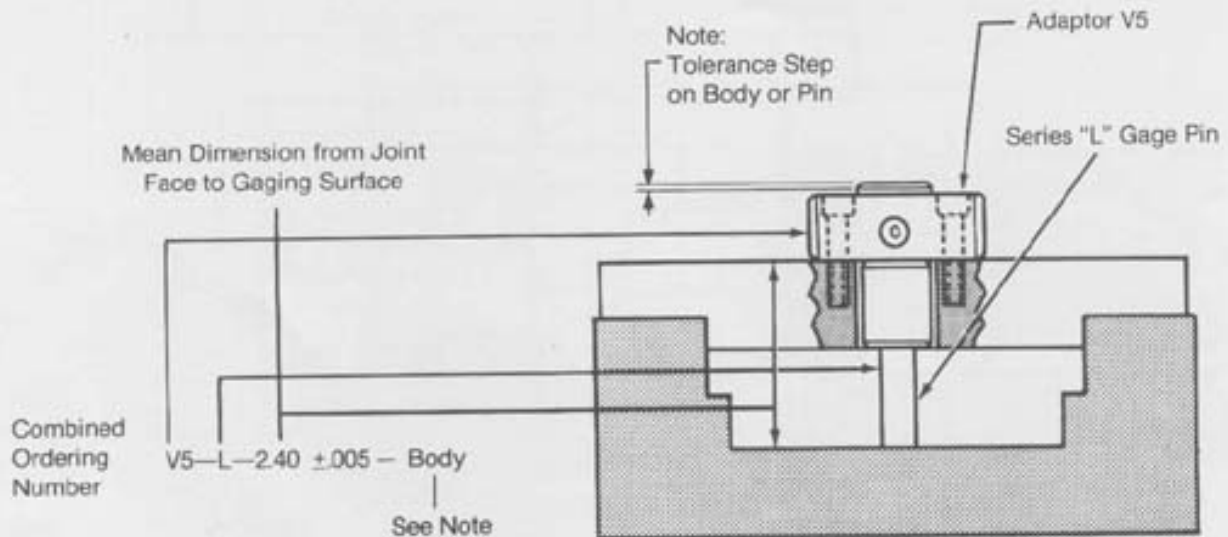

ADAPTOR PINS

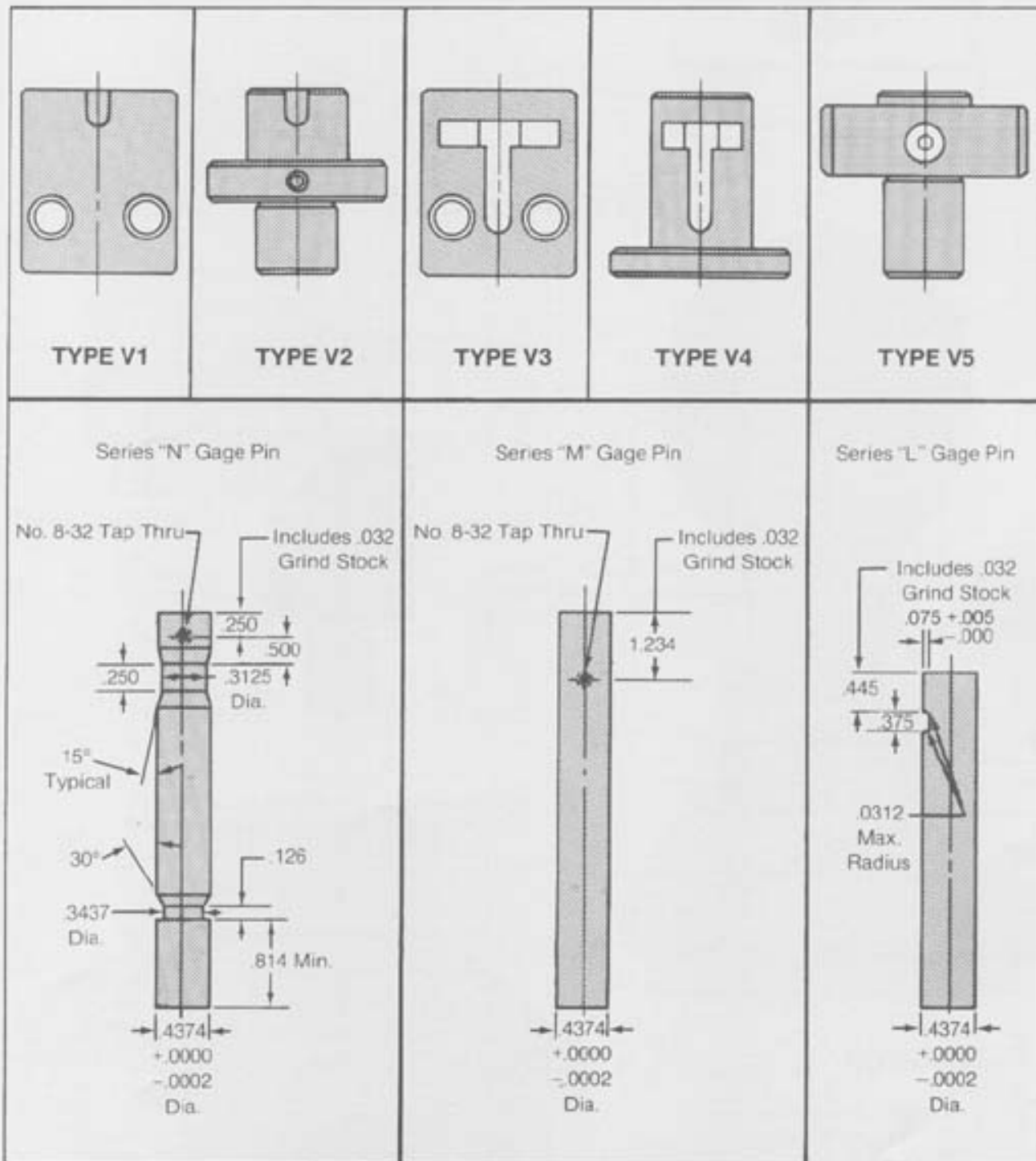

To order series "M", "N" or "L" gage pins, give mean dimension from joint face to gaging surface. For additional information, see pages 8, 9, 10, 11 and 12.



INDICATOR ADAPTOR FOR THE BARREL SERIES

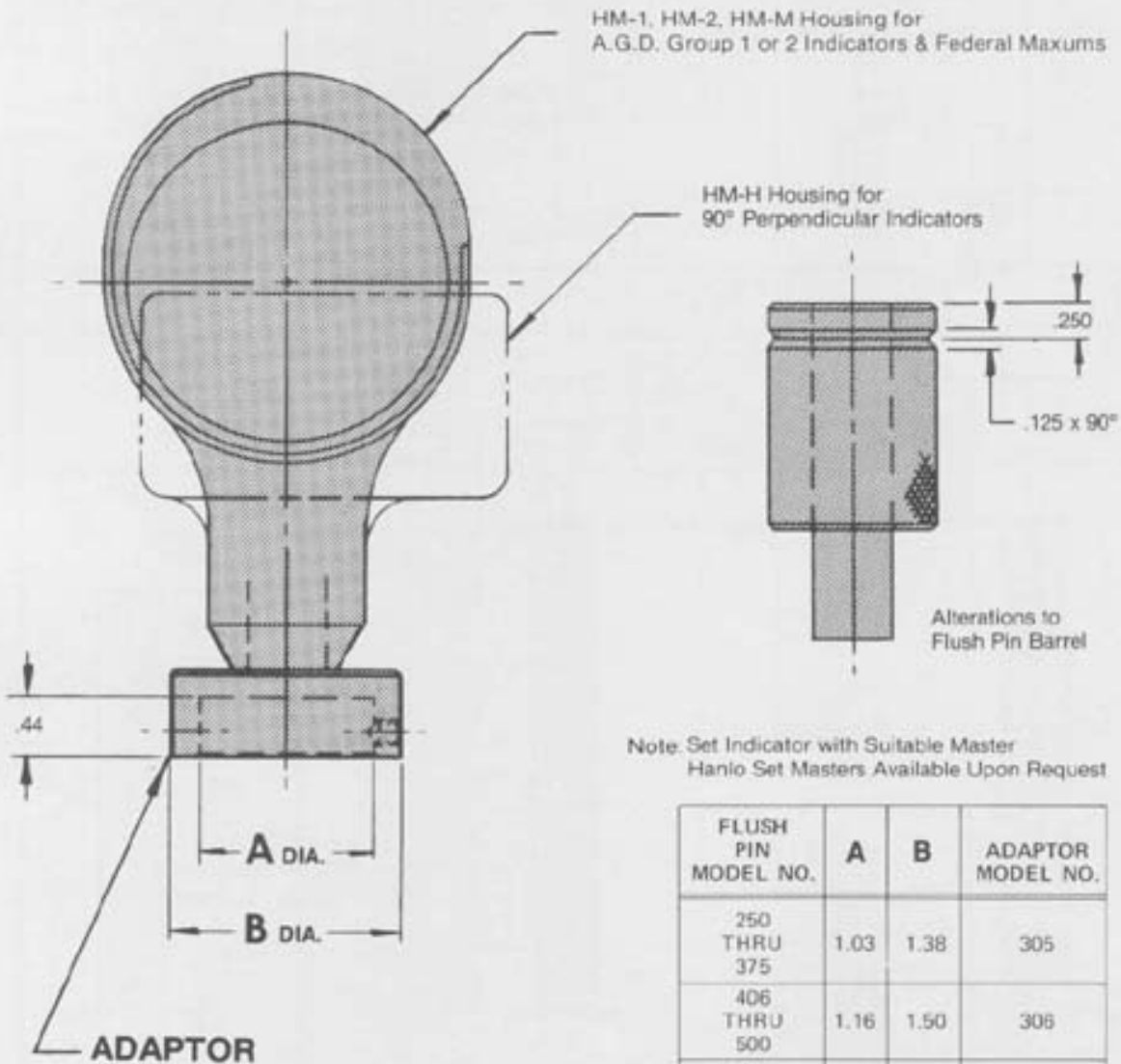

Note: Set Indicator with Suitable Master
Hario Set Masters Available Upon Request

FLUSH PIN MODEL NO.	A	B	ADAPTOR MODEL NO.
250 THRU 375	1.03	1.38	305
406 THRU 500	1.16	1.50	306
531 THRU 625	1.28	1.62	307
656 THRU 750	1.41	1.75	308

INDICATOR ADAPTOR FOR THE HC SERIES

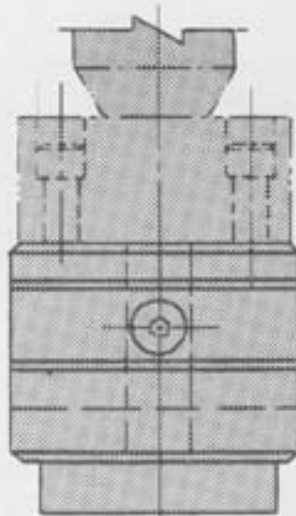

Model HC-2-1
Gage Specifications
Max. Countersink Dia.—1.50 in.
Min. Countersink Dia.—.75 in.

(2) No. 10-32 Tapped Holes
for Hanlo Model 4, 7,
or Hanlo QC Units

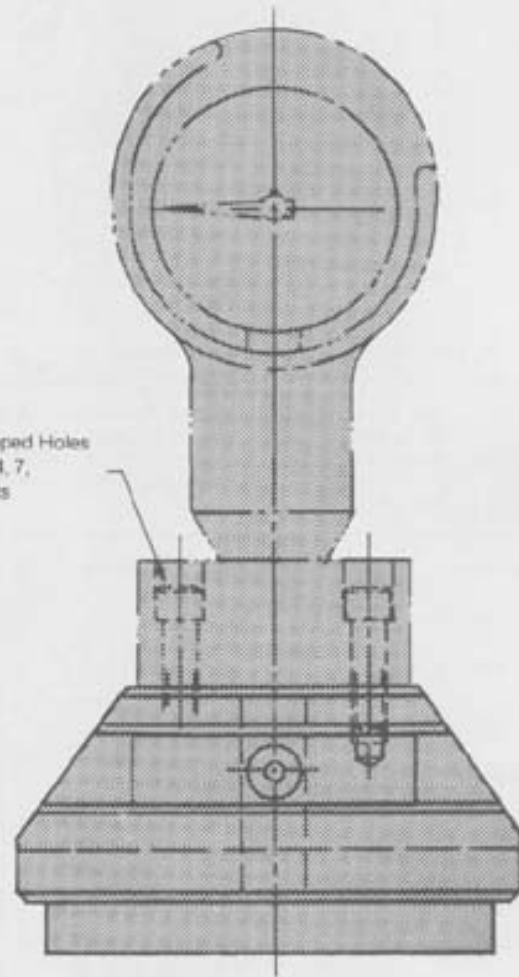

Model HC-3-1
Gage Specifications
Max. Countersink Dia.—3.00 in.
Min. Countersink Dia.—1.50 in.

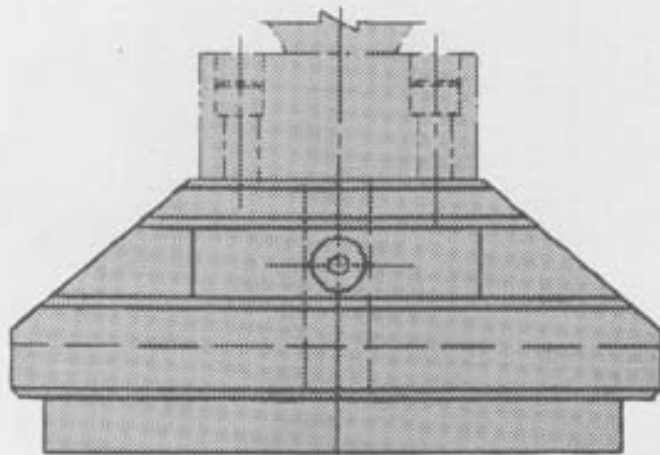

Model HC-4-1
Gage Specifications
Max. Countersink Dia.—4.00 in.
Min. Countersink Dia.—3.00 in.

Set Master Required

HANLO COMBINES COMPONENTS AND FIXTURING TO OFFER A COMPLETE GAGING SYSTEM

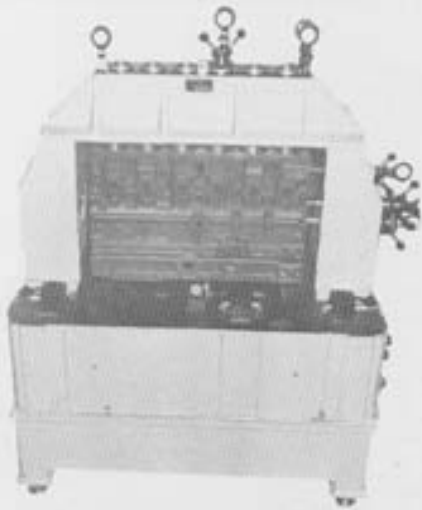

Hanlo Dog House Gage to Check: SIX CYLINDER DIESEL ENGINE BLOCK

Part is supported on air bag-elevator mechanism. Hanlo grip hydraulic arbors establish part axis. Hanlo sweep and depth gages are used to check true position of cylinder, cam and auxiliary drive bores, end and head face geometry.

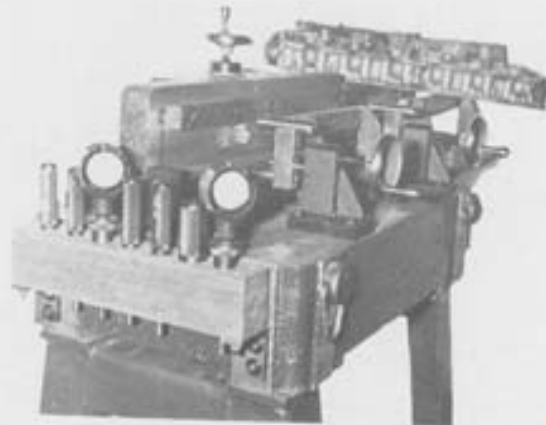

Hanlo Fixture Gage to Check: CYLINDER HEAD

Part is manually clamped in fixture to duplicate machining conditions. Hanlo sweep gages and functional pins are used to check true position of holes.

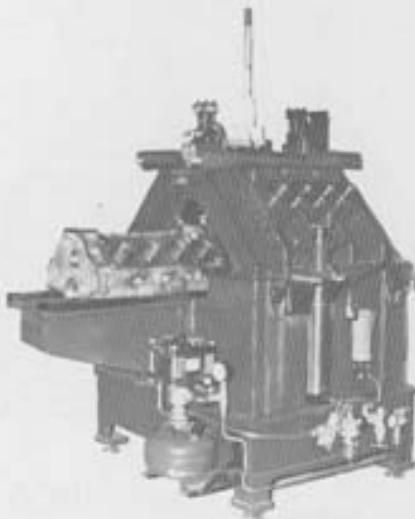

Hanlo Dog House Gage to Check: EIGHT CYLINDER ENGINE BLOCK

Part is hydraulically clamped into position to duplicate machining conditions. Hanlo air bar is used to check location of cylinder bores.



Hanlo Indicator Fixture Gage to Check: CRANKSHAFT

Runout of journal diameters and end location, in relation to centers and thrust face.

OTHER
COMPONENTS
BY

**HANLO
GAGES**

HANLO
GAGE & ENGINEERING CO.

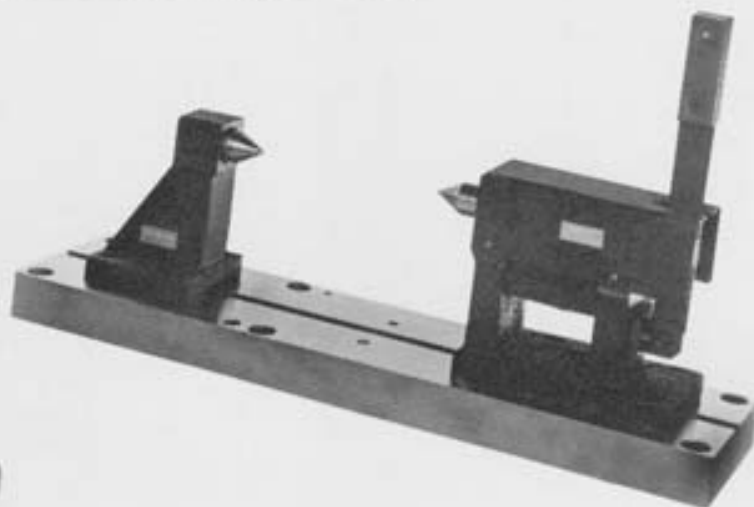

ENGINEERING & MANUFACTURING

FIXED LIMIT GAGES

INDICATOR GAGE COMPONENTS

INDICATOR GAGE ASSEMBLIES

FIXTURE GAGE COMPONENTS

ELECTRONIC GAGES

AIR GAGES

FIXTURE GAGE SYSTEMS

AUTOMATIC GAGE SYSTEMS

MASTERS

COMPLETE FACILITIES FOR REWORK & REPAIR

**HANLO
GAGES**

HANLO
GAGE & ENGINEERING CO.